

**Test Hoses and Connectors** 60 - 70

**Test Hose** SMS / SGS 62 - 63

Technical Data



**Test Hose / Hose End** SMS / SGS / HE 63

Ordering Codes



**Hose End** HE 64 - 69



**Hose Connector** SSV 70



**Sampling Hose Adaptor** SHA 70

C



Technical Data Test Hose



C

		A	B	C	D
Nominal Bore (DN)	(mm)	DN 2		DN 4	
Max. Working Pressure (PN)	(bar / PSI)	400 / 5801	630 / 9135	340 / 4931	630 / 9135
Min. Burst Pressure	(bar / PSI)	1100 / 15954	1900 / 27557	850 / 12328	1900 / 27557
Testing Pressure	(bar / PSI)	600 / 8702	950 / 13778	570 / 8267	950 / 13779
Pressure Rating in bar / PSI at Indicated Temperature	at 0 °C / 32 °F (122 %)	488 / 7077	768 / 11139	415 / 6016	768 / 11139
	at 30 °C / 86 °F (110 %)	440 / 6381	693 / 10051	374 / 5424	693 / 10051
	at 50 °C / 122 °F (100 %)	400 / 5801	630 / 9137	340 / 4931	630 / 9137
	at 80 °C / 176 °F (86 %)	344 / 4989	542 / 7861	292 / 4241	542 / 7861
	at 100 °C / 212 °F (77 %)	308 / 4467	485 / 7034	262 / 3797	485 / 7034
Working Temperature	(°C / °F)	-35 °C ... +100 °C / -31 °F ... +212 °F (momentary +120 °C / +248 °F)			
Inside Diameter	(mm / in)	2 / .08			
Outside Diameter	(mm / in)	5 / .20			
Bending Radius <sup>1</sup>	at working pressure	20 / .79			
	at -20 °C / 4 °F	30 / 1.18			
Max. Coil Length	(m / ft)	20 / 65.62			
Weight / m	(g / oz)	16 / .50			
Inner / Outer Tube		PA			
Reinforcement		Synthetic Fibre			
Standard hose end material is Steel 11 S Mn Pb 30 (1.0718), zinc/ nickel-plated (Type 15: Steel, black zinc/nickel-plated)					
Stainless Steel: V2A (1.4305/AISI 303), V4A (1.4571/AISI 316Ti) on request					

<sup>1</sup> Note: During mounting make sure that the bending radius for the test hose does not fall below the smallest permissible value.

STAUFF Test Hoses (Selection)

STAUFF-Test 20/20

STAUFF-Test 15/15

STAUFF-Test 12/12<sup>2</sup>

STAUFF-Test 10/10

Gauge Adaptor

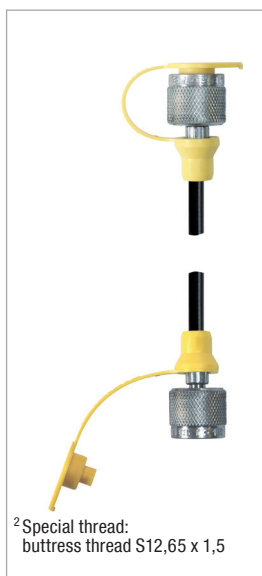

Dimensional drawings: All dimensions in mm (in).

Ordering Codes STAUFF Test Hose

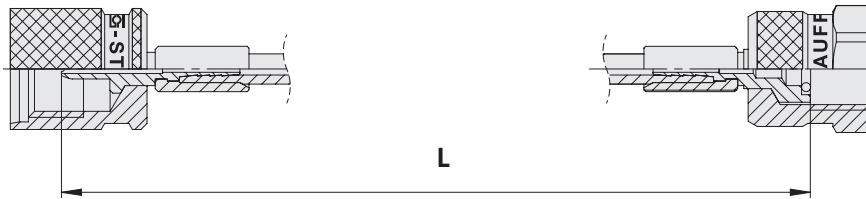

<b>SMS<sup>1</sup></b>	<b>20</b>	<b>/ M . . . .</b>	<b>3000</b>	<b>A</b>	<b>W3</b>	
Hose End 1 (see page 64 - 69)		Hose End 2 (see page 64 - 69)		Length	DN	Material Hose End
20	A . . . .	J . . . .	only specify when 2 different hose ends are required	<b>Length mm</b> (*see L above)  Standard Length see table below.	A = DN 2 400 bar / 5802 PSI B = DN 2 630 bar / 9137 PSI C <sup>2</sup> = DN 4 340 bar / 4931 PSI D <sup>2</sup> = DN 4 630 bar / 9137 PSI	Standard hose end material is Steel 11 S Mn Pb 30 (1.0718), zinc/nickel-plated = W3 Type 15: Steel, <u>black</u> zinc/nickel-plated = W3 Stainless Steel: V2A (1.4305/AISI 303) = W4, on request V4A (1.4571/AISI 316Ti) = W5, on request
15	S . . . .	D . . . .				
12	K . . . .	B . . . .				
10	L . . . .	U . . . .				
M . . . .	G . . . .	P . . . .				
N . . . .	F . . . .	etc.				
W . . . .	C . . . .					
<sup>1</sup> for gaseous media type SGS - Test hoses are perforated						
<sup>2</sup> Type C and D - are perforated						

**C**

Standard Length L*	
mm	in
200	7.87
400	15.75
630	24.80
800	31.50
1000	39.37
1500	59.06
2000	78.74
2500	98.43
3200	125.98
4000	157.48



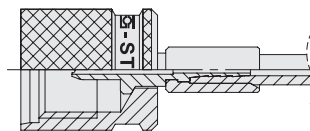

Ordering Codes Hose End

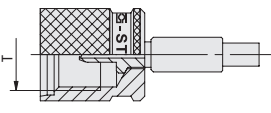
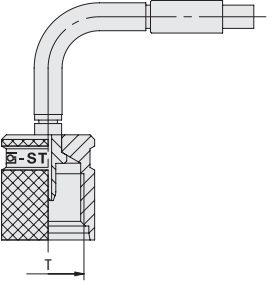
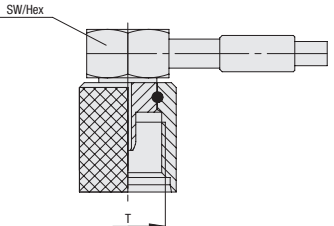

<b>HE</b>	<b>20</b>	<b>A</b>	<b>W3</b>
Hose End (see page 64 - 69)		DN	Material Hose End
20	A . . . .	J . . . .	Standard hose end material is Steel 11 S Mn Pb 30 (1.0718), zinc/nickel-plated = W3 Type 15: Steel, <u>black</u> zinc/nickel-plated = W3 Stainless Steel: V2A (1.4305/AISI 303) = W4, on request V4A (1.4571/AISI 316Ti) = W5, on request
15	S . . . .	D . . . .	
12	K . . . .	B . . . .	
10	L . . . .	U . . . .	
M . . . .	G . . . .	P . . . .	
N . . . .	F . . . .	etc.	
W . . . .	C . . . .		
		A = DN 2 C = DN 4	

STAUFF Hose End

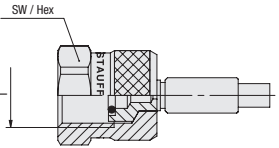
Hose End	Description	T	Hex (mm / in)	DN	Working Pressure (bar / psi) <sup>1</sup>	Type	
	STAUFF-Test Screw-type suitable for test points	M16 x 2	2 and 4	630 / 9137	20		
		M16 x 1,5				15	
		S12,65 x 1,5				12	
	STAUFF-Test Screw-type 90° elbow suitable for test points	M16 x 2	2	630 / 9137	20		
		M16 x 1,5				0 15	
		S12,65 x 1,5				12	
	STAUFF-Test Screw-type 90° elbow suitable for test points (short wire version)	M16 x 2	17 .67	2	630 / 9137	OX 15	
		M16 x 1,5					12
		S12,65 x 1,5					12
	STAUFF-Test Plug in-type	Plug In System		2	400 / 5801	10	
	Gauge adaptor BSP-thread for G3/8, G1/2, M14 x 1,5 and M20 x 1,5 swivel nut like type N	G1/4	19 .75	2 and 4	630 / 9137	1/4	
		G1/2					27 1.06
		G3/8	22 .87	2	630 / 9137	M	3/8
		M14 x 1,5	19 .75				14
		M20 x 1,5	27 1.06				20

<sup>1</sup> The indicated working pressure applies only to the Hose End. The actual working pressure depends on the Test Hose used.

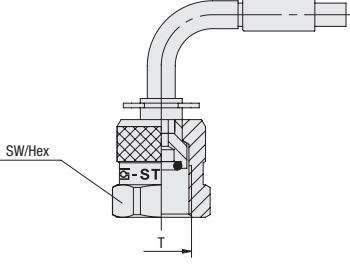
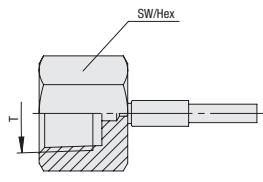
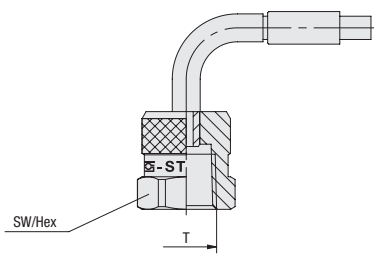
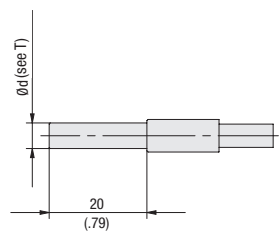
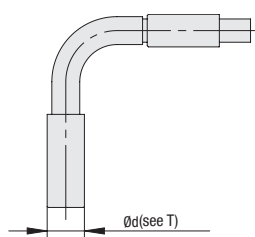
Hose End	Description	T	Hex (mm / in)	DN	Working Pressure (bar / psi) <sup>1</sup>	Type	
	90° elbow gauge adaptor BSP-thread  for G1/2 swivel nut like type N	G1/4	19	.75	630 / 9137	W	
		G1/2	27	1.06			
	Gauge adaptor NPT-thread  for 1/4 NPT swivel nut like type M	1/4 NPT	19	.75	2	N	
		1/2 NPT	27	1.06			
	90° elbow gauge adaptor NPT-thread  for 1/2 NPT swivel nut like type N	1/4 NPT	19	.75	2 and 4	A	
		1/2 NPT	27	1.06			
	Standpipe for compression ring fittings according to ISO 8434-1 / DIN 2353  Note: Standpipe version is not in accordance with the state of the art. Use at own risk. We recommend the use of the series K, R or L.	4 LL			2	04	
		6 L - 6 S			630 / 9137	S	06
		8 L - 8 S		2 and 4			08
		10 L - 10 S					10
		12 L - 12 S		2			12
		1/4		2 and 4	1/4		
	Standpipe for compression ring fittings according to ISO 8434-1 / DIN 2353 90° elbow  Note: Standpipe version is not in accordance with the state of the art. Use at own risk. We recommend the use of the series K, R or L.	6 L - 6 S			2 and 4	630 / 9137	06
		8 L - 8 S					08

<sup>1</sup> The indicated working pressure applies only to the Hose End. The actual working pressure depends on the Test Hose used.

STAUFF Hose End

Hose End	Description	T	Hex (mm/in)	DN	Working Pressure ( <sup>bar</sup> /PSI) <sup>1</sup>	Type	
	Seal with O-ring for 24° cone fitting according to ISO 8434-1 / DIN 2353 c/w swivel nut	M12 x 1,5	14 .55	2 and 4	315 / 4568	K	06L
		M14 x 1,5	17 .67				08L
		M16 x 1,5	19 .75				10L
		M18 x 1,5	22 .87				12L
		M14 x 1,5	17 .67		630 / 9137	06S	
		M16 x 1,5	19 .75			08S	
		M18 x 1,5	22 .87			10S	
		M20 x 1,5	24 .94			12S	
	Seal with O-ring for 24° cone fitting according to ISO 8434-1 / DIN 2353 c/w swivel nut 45° elbow	M12 x 1,5	14 .55	2 and 4	315 / 4568	R	06L
		M14 x 1,5	14 .67				06S
	Seal with O-ring for 24° cone fitting according to ISO 8434-1 / DIN 2353 c/w swivel nut 90° elbow	M12 x 1,5	14 .55	2 and 4	315 / 4568	L	06L
		M14 x 1,5	17 .67				08L
		M16 x 1,5	19 .75				10L
		M14 x 1,5	17 .67		630 / 9137		06S
		M16 x 1,5	19 .75				08S
		M18 x 1,5	24 .94				10S
	Male thread according to DIN 3852-B	M12 x 1,5	17 .67	2 and 4	630 / 9137	G	12
		G1/8	14 .55		400 / 5801		1/8
		G1/4	19 .75		630 / 9137		1/4
		G1/2	27 1.06		630 / 9137		1/2
	Male thread NPT according to ANSI-standard	1/8 NPT	13 .51	2 and 4	400 / 5801	F	1/8
		1/4 NPT	17 .67		630 / 9137		1/4

<sup>1</sup>The indicated working pressure applies only to the Hose End. The actual working pressure depends on the Test Hose used.

Hose End	Description	T	Hex (mm/in)	DN	Working Pressure ( <sup>bar</sup> /psi) <sup>1</sup>	Type
	Male thread for 24° cone fitting according to ISO 8434-1 / DIN 2353	M12 x 1,5	14 .55	2 and 4	315 / 4568	06L
		M14 x 1,5	17 .67			08L
		M14 x 1,5	17 .67		630 / 9137	06S
		M16 x 1,5	17 .67			08S
	Male thread according to SAE J 514	7/16-20 UNF	14 .55	2 and 4	350 / 5076	J 1/4
		1/2-20 UNF	14 .55			J 5/16
		9/16-18 UNF	17 .67			J 3/8
	Universal sealing head with swivel nut for 24° cone fitting according to ISO 8434-1 / DIN 2353	M12 x 1,5	14 .55	2 and 4	315 / 4568	D 06L
		M14 x 1,5	17 .67			D 08L
		M16 x 1,5	19 .75			D 10L
		M18 x 1,5	22 .87		630 / 9137	D 12L
		M14 x 1,5	17 .67			D 06S
		M16 x 1,5	19 .75			D 08S
		M18 x 1,5	22 .87			D 10S
M20 x 1,5	24 .94	D 12S				
	Universal sealing head with swivel nut for 24° cone fitting according to ISO 8434-1 / DIN 2353 90° elbow	M16 x 1,5	19 .75	2 and 4	315 / 4568	Q 10L
		M18 x 1,5	22 .87			Q 10S
	Sealing head with swivel nut for cone fitting according to DIN EN 560	G1/8	12 .47	2 and 4	/	B 1/8
		G1/4	17 .67			B 1/4

<sup>1</sup> The indicated working pressure applies only to the Hose End. The actual working pressure depends on the Test Hose used.



STAUFF Hose End

Hose End	Description	T	Hex (mm / in)	DN	Working Pressure ( <sup>bar</sup> / <sup>PSI</sup> ) <sup>1</sup>	Type
	Sealing head with swivel nut according to SAE J 514 37° cone	7/16–20 UNF	14 .55	2 and 4	350 / 5076	U 1/4
		1/2–20 UNF	17 .67			U 5/16
		9/16–18 UNF	19 .75			U 3/8
	Sealing head with swivel nut according to SAE J 516 45° cone	7/16–20 UNF	14 .55	2		UR 1/4
	Sealing head with swivel nut according to SAE J 514 37° cone 90° elbow	7/16–20 UNF	14 .55	2 and 4	350 / 5076	E 1/4
	Sealing head with swivel nut according to SAE J 516 45° cone 90° elbow	7/16–20 UNF	14 .55	2		ER 1/4
	Test hose for air brake systems according to ISO 3583	M16 x 1,5	19 .75	2		P 02

<sup>1</sup> The indicated working pressure applies only to the Hose End. The actual working pressure depends on the Test Hose used.

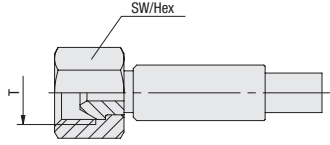
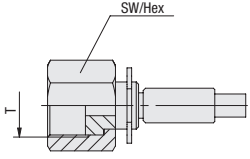
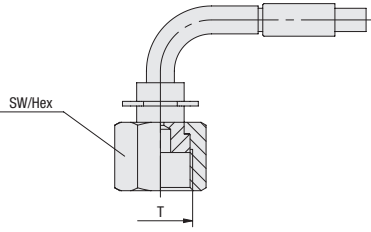
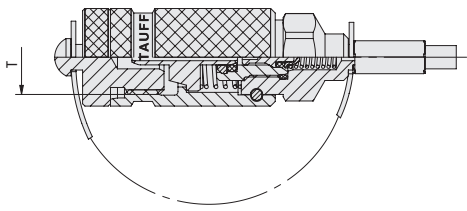
Hose End	Description	T	Hex (mm / in)	DN	Working Pressure ( <sup>bar</sup> / <sup>PSI</sup> ) <sup>1</sup>	Type
	Sealing head with swivel nut 60° cone	G1/4	17 .67	2 and 4	630 / 9137	H 1/4
	Screw-type ORFS according to SAE J 1453	9/16-18 UNF	17 .67	2		T 9/16
		11/16-16 UN	21 .83			T 11/16
	Screw-type ORFS according to SAE J 1453 90° elbow	11/16-16 UN	21 .83	2 and 4		V 11/16
	Hose end with integrated check valve	M16 x 2		2	630 / 9137	RV 20
		M16 x 1,5				RV 15

**C**

<sup>1</sup> The indicated working pressure applies only to the Hose End. The actual working pressure depends on the Test Hose used.

### Hose Connector SSV

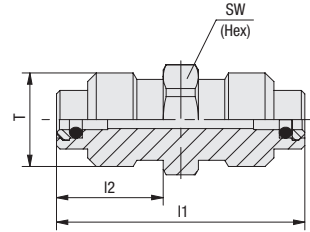
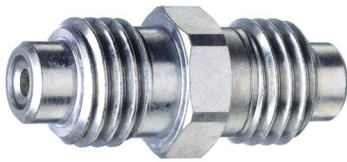

C

#### Ordering Codes

##### \*SSV\*-20\*-W3

* Type	Hose Connector	<b>SSV</b>
* Series	STAUFF Test 20	<b>-20</b>
	STAUFF Test 15	<b>-15</b>
	STAUFF Test 12	<b>-12</b>
* Material Code	Steel, zinc/nickel-plated	<b>-W3</b>
	Stainless Steel V2A - 1.4305 (AISI 303)	<b>-W4</b>
	Stainless Steel V4A - 1.4571 (AISI 316 Ti)	<b>-W5</b>

Thread	Dimensions (mm/in)			Weight (kg/lbs) ca. per 100	Ordering Codes (Standard Option)
	I1	I2	Hex		
M16 x 2	42,5	18,5	17	4,60	SSV-20-W3
	1.67	.73	.67	10.12	
M16 x 1,5	42,5	18,5	17	4,79	SSV-15-W3
	1.67	.73	.67	10.54	
S12,65 x 1,5	31	12,5	14	2,50	SSV-12-W3
	1.22	.49	.55	5.50	

Alternative materials and surface finishings are available upon request. Contact STAUFF for further information.

### Sampling Hose Adaptor SHA

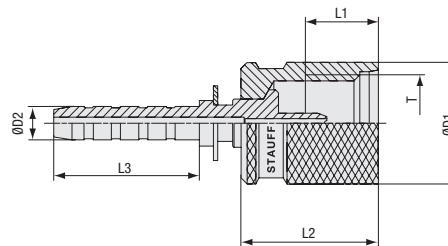

#### Ordering Codes

##### \*SHA\*-20\*-5.5MM\*-W3

* Type	Sampling Hose Adaptor	<b>SHA</b>
* Series	STAUFF Test 20	<b>-20</b>
* Size	Hose nipples	<b>-5.5MM</b>
* Material Code	Steel, zinc/nickel-plated	<b>-W3</b>
	Stainless Steel V2A - 1.4305 (AISI 303)	<b>-W4</b>
	Stainless Steel V4A - 1.4571 (AISI 316 Ti)	<b>-W5</b>

Dimensions (mm/in)						Weight (kg/lbs) ca. per 100	Ordering Codes (Standard Option)
Ød1	Ød2	I1	I2	I3	T		
22	5,5	13	23	24	M16 x 2	3,36	SHA-20-5.5MM-W3
.87	.22	.51	.91	.94		7.39	

Alternative materials and surface finishings are available upon request. Contact STAUFF for further information.



Dimensional drawings: All dimensions in mm (in).



<b>Port Dimensions and Seal Types</b>	<b>74 - 77</b>
Type A	74
Type B	75
Type C	75
Type D	76
Type E	77

Port Dimensions and Seal Types

D

Type A

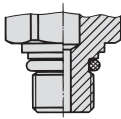

with O-ring

Factory standard

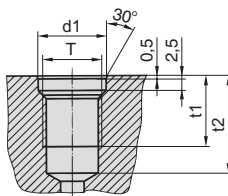

Port Factory standard

Type A

Dimensions

(mm/in)

Thread T	d1 +0,1	t1 min.	t2 min.
M8 x 1	9,5 .37	11 .43	15,5 .61
M10 x 1	11,5 .45	12 .47	16,5 .64



Dimensional drawings: All dimensions in mm (in).

## Port Dimensions and Seal Types

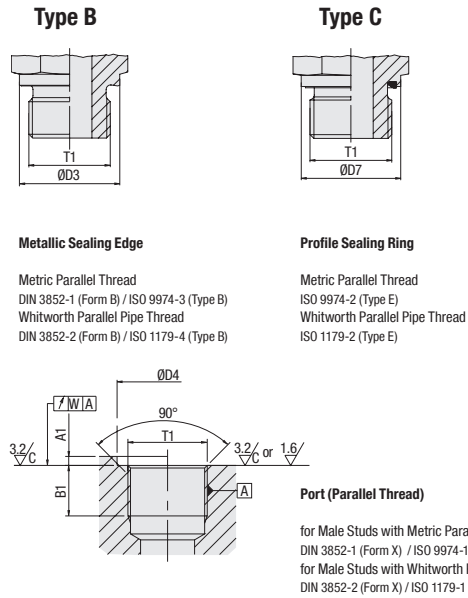
**Dimensions**

(mm/in)

Thread T1 <sup>1</sup>	D3	D7 <sub>-0,2</sub>	D4 small <sub>min</sub>	D4 wide <sub>min</sub>	A1 <sub>max</sub>	B1 <sub>min</sub>	W
M 10 x 1	14 .55	13,9 .55	15 .59	20 .79	1 .04	8 .31	0,1 .0039
M 12 x 1,5	17 .67	16,9 .67	18 .71	25 .98	1,5 .06	12 .47	0,1 .0039
M 14 x 1,5	19 .75	18,9 .74	20 .79	25 .98	1,5 .06	12 .47	0,1 .0039
M 16 x 1,5	21 .83	21,9 .86	23 .91	28 1.10	1,5 .06	12 .47	0,1 .0039
M 18 x 1,5	23 .91	23,9 .94	25 .98	30 1.18	2 .08	12 .47	0,1 .0039
M 20 x 1,5	24 .94	25,9 1.02	27 1.06	34 1.34	2 .08	14 .55	0,1 .0039
M 22 x 1,5	27 1.06	26,9 1.06	28 1.10	34 1.34	2,5 .10	14 .55	0,1 .0039
G 1/8 A	14 .55	13,9 .55	15 .59	19 .75	1 .04	8,5 .33	0,1 .0039
G 1/4 A	18 .71	18,9 .74	20 .79	25 .98	1,5 .06	12,5 .49	0,1 .0039
G 3/8 A	22 .87	21,9 .86	23 .91	28 1.10	2 .08	12,5 .49	0,1 .0039
G 1/2 A	26 1.02	26,9 1.06	28 1.10	34 1.34	2,5 .10	15 .59	0,1 .0039

<sup>1</sup> Appendix A in the thread description does not apply to (female) threaded ports.

## Port Dimensions and Seal Types

D

### Type D

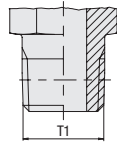

**Taper Thread**

National Pipe Thread (NPT)  
ANSI/ASME B1.20.1-1983

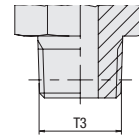

**Taper Thread**

Metric Taper Thread  
DIN 3852-1 (Form C)  
Whitworth Taper Pipe Thread  
DIN 3852-2 (Form C)

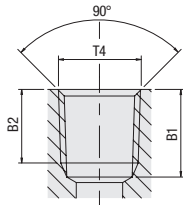

**Port (Taper Thread)**

for Male Studs with National Pipe NPT Thread  
ANSI/ASME B1.20.1-1983

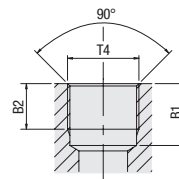

**Port (Parallel Thread)**

for Male Studs with Metric Taper Thread  
DIN 3852-1 (Form Z)  
for Male Studs with Whitworth Taper Pipe Thread  
DIN 3852-2 (Form Z)

#### Dimensions

(mm/in)

Thread T1	Thread T3	Thread T4	B1 <sub>min</sub>	B2 <sub>min</sub>
1/8-27 NPT		1/8-27 NPT		6,9 .27
1/4-18 NPT		1/4-18 NPT		10 .39
1/2-14 NPT		1/2-14 NPT		13,6 .54
	R 1/8 keg.	Rp 1/8	8,5 .33	5,5 .22
	R 1/4 keg.	Rp 1/4	12,5 .49	8,5 .33
	R 3/8 keg.	Rp 3/8	12,5 .49	8,5 .33
	R 1/2 keg.	Rp 1/2	16,5 .65	10,5 .41

Suitable liquid / plastic sealant required to achieve leak-tightness.



Dimensional drawings: All dimensions in mm (in).



## Port Dimensions and Seal Types

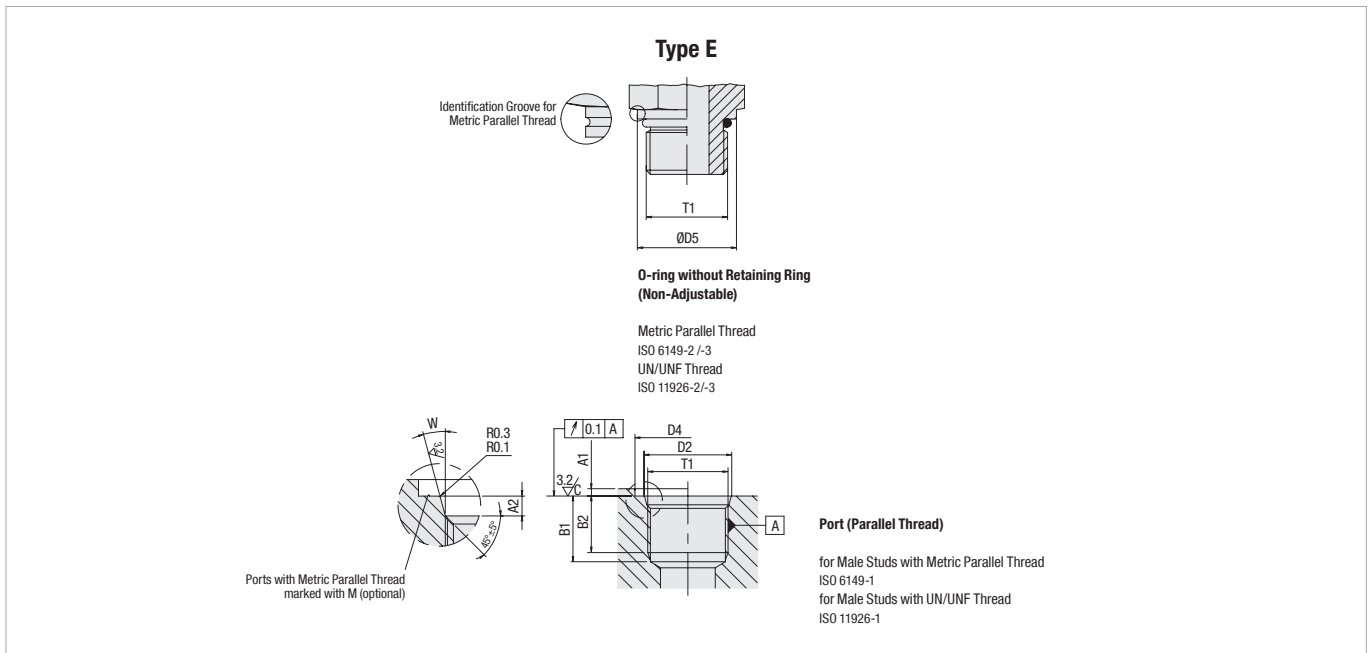

<b>Dimensions</b>										
(mm/in)										
Thread T1 <sup>1</sup>	D5	D4 small <sub>min</sub>	D4 wide <sub>min</sub>	D2 <sub>+0,1 (UNF: ±0,05)</sub>	A1 <sub>max</sub>	A2 <sub>+0,4</sub>	B1 <sub>min</sub>	B2 <sub>min</sub>	W <sub>±1*</sub>	
M 10 x 1	13,8	16	20	11,1	1	1,6	11,5	10	12	
	.54	.63	.79	.44	.04	.06	.45	.39	.47	
M 12 x 1,5	16,8	19	23	13,8	1,5	2,4	14	11,5	15	
	.66	.75	.91	.54	.06	.09	.55	.45	.59	
M 14 x 1,5	18,8	21	25	15,8	1,5	2,4	14	11,5	15	
	.74	.83	.98	.62	.06	.09	.55	.45	.59	
M 16 x 1,5	21,8	24	28	17,8	1,5	2,4	15,5	13	15	
	.86	.94	1.10	.70	.06	.09	.61	.51	.59	
M 22 x 1,5	26,8	29	33	23,8	2	2,4	18	15,5	15	
	1.06	1.14	1.30	.94	.08	.09	.71	.61	.59	
M 27 x 2	31,8	34	40	29,4	2	3,1	22	19	15	
	1.25	1.34	1.57	1.16	.08	.12	.87	.75	.59	
5/16-24 UNF-2A	11,1	17		9,1	1,6	1,9	10	12	12	
	.43	.66		.35	.06	.07	.39	.47	.47	
7/16-20 UNF-2A	14,4	21		12,45	1,6	2,4	14	11,5	12	
	.57	.83		.49	.06	.09	.55	.45	.47	
1/2-20 UNF-2A	16	23		14,05	1,6	2,4	14	11,5	12	
	.63	.91		.55	.06	.09	.55	.45	.47	
9/16-18 UNF-2A	17,6	25		15,7	1,6	2,5	15,5	12,7	12	
	.69	.98		.62	.06	.10	.61	.50	.47	
3/4-16 UNF-2A	21,8	30		20,65	2,4	2,5	17,5	14,3	15	
	.86	1.18		.81	.09	.10	.69	.56	.59	
7/8-14 UNF-2A	26,8	34		24,0	2,4	2,5	20	16,7	15	
	1,06	1.34		.94	.09	.10	.79	.66	.59	

<sup>1</sup> Appendix -2B instead of -2A applies for (female) threaded ports.



Product-Specific Abbreviations 80 - 81

Global Contact Directory 82 - 83

## Product-Specific Abbreviations

Abbreviation	Product Category	Product Description	Page
EMV	Test Adaptors	Adjustable Gauge Fitting	59
HE	Test Hoses and Connectors	STAUFF Test Screw-type	64
HE	Test Hoses and Connectors	STAUFF Test Plug in-type	64
HE-A	Test Hoses and Connectors	Gauge adaptor NPT-thread, 90° elbow, Hose End	65
HE-B	Test Hoses and Connectors	Sealing head with swivel nut for cone fitting according to DIN EN 560, Hose Ends	67
HE-C	Test Hoses and Connectors	Male thread for 24° cone fitting according to ISO 8434-1 / DIN 2353, Hose End	67
HE-D	Test Hoses and Connectors	Universal sealing head with swivel nut for 24° cone fitting according to ISO 8434-1 / DIN 2353, Hose End	67
HE-E	Test Hoses and Connectors	Sealing head with swivel nut according to SAE J 514, 37° cone, 90° elbow, Hose End	68
HE-ER	Test Hoses and Connectors	Sealing head with swivel nut according to SAE J 516, 45° cone, 90° elbow, Hose End	68
HE-F	Test Hoses and Connectors	Male thread NPT according to ANSI Standard, Hose End	66
HE-G	Test Hoses and Connectors	Male thread according to DIN 3852-B, Hose End	66
HE-H	Test Hoses and Connectors	Sealing head with swivel nut, 60° cone, Hose End	69
HE-J	Test Hoses and Connectors	Male thread according to SAE J 514, Hose End	67
HE-K	Test Hoses and Connectors	Seal with O-ring for 24° cone fitting according to ISO 8434-1 / DIN 2353, c/w swivel nut, Hose End	66
HE-L	Test Hoses and Connectors	Seal with O-ring for 24° cone fitting according to ISO 8434-1 / DIN 2353, c/w swivel nut, 90° elbow, Hose End	66
HE-M	Test Hoses and Connectors	Gauge adaptor BSP-thread, Hose End	64
HE-N	Test Hoses and Connectors	Gauge adaptor NPT-thread, Hose End	65
HE-O	Test Hoses and Connectors	STAUFF Test Screw-type, 90° elbow, suitable for test points, Hose End	64
HE-OX	Test Hoses and Connectors	STAUFF Test Screw-type, 90° elbow, suitable for test points (short wire version), Hose End	64
HE-P	Test Hoses and Connectors	Test hose for air brake systems, Hose End	68
HE-Q	Test Hoses and Connectors	Universal sealing head with swivel nut for 24° cone fitting according to ISO 8434-1 / DIN 2353, 90° elbow, Hose End	67
HE-R	Test Hoses and Connectors	Seal with O-ring for 24° cone fitting according to ISO 8434-1 / DIN 2353, c/w swivel nut, 45° elbow, Hose End	66
HE-RV	Test Hoses and Connectors	Hose End with integrated check valve, Hose End	69
HE-S	Test Hoses and Connectors	Standpipe for compression ring fittings according to ISO 8434-1 / DIN 2353, Hose End	65
HE-SG	Test Hoses and Connectors	Standpipe for compression ring fittings according to ISO 8434-1 / DIN 2353, 90° elbow, Hose End	65
HE-T	Test Hoses and Connectors	Screw-type ORFS according to SAE J 1453, Hose End	69
HE-U	Test Hoses and Connectors	Sealing head with swivel nut according to SAE J 514, 37° cone, Hose End	68
HE-UR	Test Hoses and Connectors	Sealing head with swivel nut according to SAE J 516, 45° cone, Hose End	68
HE-V	Test Hoses and Connectors	Screw-type ORFS according to SAE J 1453, 90° elbow, Hose End	69
HE-W	Test Hoses and Connectors	Gauge adaptor BSP-thread, 90° elbow, Hose End	65
SAD-12	Test Coupling STAUFF Test 12	Test Adaptor	46
SAD-15	Test Coupling STAUFF Test 15	Test Adaptor	38
SAD-20	Test Coupling STAUFF Test 20	Test Adaptor	24
SAS	Test Adaptors	Welding Adaptor	58
SGS	Test Hoses and Connectors	Test Hose	63
SGV-JIC Type FM	Test Coupling STAUFF Test 20	Swivel Run Tee with 37° JIC Connection	22
SGV-JIC Type FM	Test Coupling STAUFF Test 15	Swivel Run Tee with 37° JIC Connection	37
SGV-JIC Type FM	Test Coupling STAUFF Test 12	Swivel Run Tee with 37° JIC Connection	45
SHA	Test Hoses and Connectors	Sampling Hose Adaptor	70
SKK-12	Test Coupling STAUFF Test 12	Test Coupling with Male Threaded Stud	42
SKK-12 Type G	Test Coupling STAUFF Test 12	Test Coupling with Straight 24° Fitting	43
SKK-12 Type K	Test Coupling STAUFF Test 12	Test Coupling with 24° Taper / O-ring (DKO)	44
SSK-15	Test Coupling STAUFF Test 15	Bulkhead	37
SKK-20	Test Coupling STAUFF Test 20	Test Coupling with Male Threaded Stud	28
SKK-20 Type G	Test Coupling STAUFF Test 20	Test Coupling with Straight 24° Fitting	29
SKK-20 Type K	Test Coupling STAUFF Test 20	Test Coupling with 24° Taper / O-ring (DKO)	31
SMA-10	Test Coupling STAUFF Test 10	Gauge Adaptor	50
SMA-12	Test Coupling STAUFF Test 12	Gauge Adaptor	46
SMA-15	Test Coupling STAUFF Test 15	Gauge Adaptor	38
SMA-20	Test Coupling STAUFF Test 20	Gauge Adaptor	25
SMD-12	Test Coupling STAUFF Test 12	Direct Gauge Adaptor	46
SMD-15	Test Coupling STAUFF Test 15	Direct Gauge Adaptor	38
SMD-20	Test Coupling STAUFF Test 20	Direct Gauge Adaptor	25
SMK-10	Test Coupling STAUFF Test 10	Test Coupling with Male Threaded Stud	50
SMK-10 Type G	Test Coupling STAUFF Test 10	Test Coupling with Straight 24° Fitting	51
SMK-10 Type K	Test Coupling STAUFF Test 10	Test Coupling with 24° Taper / O-ring (DKO)	52
SMK-15	Test Coupling STAUFF Test 15	Test Coupling with Male Threaded Stud	34
SMK-15 Type G	Test Coupling STAUFF Test 15	Test Coupling with Straight 24° Fitting	35
SMK-15 Type K	Test Coupling STAUFF Test 15	Test Coupling with 24° Taper / O-ring (DKO)	36
SMK-20	Test Coupling STAUFF Test 20	Test Coupling with Male Threaded Stud	16
SMK-20 Type G	Test Coupling STAUFF Test 20	Test Coupling with Straight 24° Fitting	17
SMK-20 Type K	Test Coupling STAUFF Test 20	Test Coupling with 24° Taper / O-ring (DKO)	19
SMK-20 Type ORFS	Test Coupling STAUFF Test 20	Test Coupling with ORFS Connection	23
SMK-20-JIC Type G	Test Coupling STAUFF Test 20	Test Coupling with Straight 37° JIC Connection	21
SMK-20-JIC Type K	Test Coupling STAUFF Test 20	Test Coupling with 37° JIC Connection	20
SMS	Test Hoses and Connectors	Test Hose	63
SRS-15	Test Adaptors	Thread Adaptor	57
SRS-20	Test Adaptors	Thread Adaptor	56
SSK-20	Test Coupling STAUFF Test 20	Bulkhead	24
SSKK-12	Test Coupling STAUFF Test 12	Bulkhead	45
SSV	Test Hoses and Connectors	Hose Connector	70